

C9000 SERIES.



C9305 TS – C9305 TSB
C9306 TS – C9306 TSB



C9000 SERIES.

Cab.

The Commander Cab VI let your combine be fully integrated and connected: the powerful 8" iMonitor in combination with the multi-functional armrest gives you the full control of all parameters and device. spacious driving position and maximum visibility for complete control of the whole width of the cutting header. > PAGE 04

.....

Engine.

The Mercedes engines – 353 / 381 HP (260 / 280 kW) – are equipped with state-of-the-art exhaust gas cleaning with EGR, DPF and SCR systems, common rail injection, 24 valves and electronic control. They deliver precisely the required power under changing loads – even at peak loads. > PAGE 34

.....

Cutting bar.

The high-performance cutting bars are manufactured from a single piece – up to 9 metres wide – and ensure optimum weight distribution and maximum power during all harvest conditions. The large reel automatically adapts to the driving speed. Maxi-Crop system, extra feeding channel and long straw walkers optimise the threshing performance. > PAGE 16

.....

Experience meets innovation. The new Topliner.

Over 100 years of experience in building state-of-the-art agricultural machinery have gone into the development of the DEUTZ-FAHR C9000 series. In combination with innovative new products and an eye even for the smallest detail, a high-tech harvester was created, equipped with everything that large modern combine harvesters have to offer today: excellent productivity, extreme versatility, maximum

functionality, elegant design and maximum working and operating convenience. The C9000 SERIES features powerful Mercedes-Benz engines, low fuel consumption, extraordinarily low running costs and very simple maintenance. Peak performance for each application, for any crop – in every respect: the DEUTZ-FAHR C9000 large combine harvesters.





Grain tank.

Two feed screws within the grain tank (10,500 litres) as well as one with an especially large diameter in the drain pipe generate maximum speed during unloading (120 litres per second). Lighting and camera on the grain tank pipe for monitoring the draining process. > PAGE 30

Threshing system.

The DEUTZ-FAHR trade Mark is the threshing system. Great versatility thanks to the independent concave settings and the configurations option, the unique segmented concave let adapt the threshing system in blink of an eye. Up to 1,52 m working width for the 6 SW models, great separation surface thanks to the big 600 mm diameter of the drum and the 121° wrapping angle of the concave. Last but not least the Turbo Separator, where foreseen, increase the productivity of the combine of 20%. The combination of the Extra Feeding system increase further more the performance of the C9000 range, the real TOPLINER. > PAGE 26

Cleaning system.

A perfect grain quality is what every farmer deserves and that is exactly what a DEUTZ-FAHR combine does. Thanks to it's great ventilation system, the double cascade preparation pan, the variety of sieves types available, and the patent DGR system, no condition is too extreme for a DEUTZ-FAHR. > PAGE 28

C9300 SERIES	C9305TS	C9305TSB	C9306TS	C9306TSB
Straw walkers	5			
Engine Stage V	Mercedes Benz OM936 7.7l			
Maximum Power kW/HP	260 / 353		280 / 381	
Grain tank capacity l	10,500			

More than 100 year of experience, loyal customers and top performance: The Legacy and the Future of the only DEUTZ-FAHR Topliner.

For further technical data, kindly refer to PAGES 42 – 48.





There are 1000 practical reasons to choose the large combine harvesters from the C9000 series. Reason number 1001 is shown on the left.



↑ Easy access to the cabin thanks to the new ladder with automatic folding and unfolding system.

↑ Up to 10 working lights on the cabin, rear and side



NEW COMMANDER CAB VI.

Intelligent as always – optimised with numerous innovations.

An aesthetic value that is immediately visible and perceptible, long lasting and always up to date. Heat reflecting windows, sun visor, sculptured roof with sufficient overhang on the sides are a guarantee of shade and a pleasant operating atmosphere in the cab. Moreover, the presence of a maintenance handrail on both cab uprights allows dust to be cleaned from the windscreen. Tall telescopic electrically adjustable rear view mirrors with twin mirror glass removes potential "Blind spots" and provide safer, clearer rear vision. Two rotating beacons complete the standard equipment. The new ladder grants easy access. The compact overall width of the combine is maintained due to the automatic rotating system which stows the ladder under the cab. A large hand-rail assists access further and while not in use, the rail can be folded to prevent any collision with branches and other obstacles.



lights ensure TOP visibility during night harvesting



DESIGN AND ERGONOMICS.

For maximum working convenience.



↑ Extra large seat with integrated multifunctional armrest for TOP comfort and controls.



↑ Backlit controls for TOP visibility and accessibility.



↑ Second iMonitor for Agrosky, Yield monitoring and camera views.



↑ 21 litre portable fridge placed under the second driver seat standard on all versions.



With the customer needs clear in mind, the new COMMANDER CAB VI offers great comfort and the state of the art in terms of on board systems. Plain design with soft material in light grey to assure a relaxing and excellent work environment. Spacious driving position and maximum visibility for complete control of the whole width of the

cutting header. Camera kits with up to 3 cameras to monitor the area surrounding the combine. All the cameras are colour and infrared, the images are displayed on the new 7" monitor or in the 12" iMonitor (standard with Agrosky).



TOP COMBINE MANAGEMENT.

Intuitive, precise and convenient operation of all systems.



The great DEUTZ-FAHR experience in searching for the best, easiest and fastest way to manage and face the daily tasks on a combine, is now condensed in the new multifunctional armrest equipped on the C9300 series.



↑ The COMMANDER STICK, controls all main functions of the combine:

- Header position
- Reel position and speed
- Unloading tube (position and discharge)
- Cruise control

The COMMANDER STICK also integrates the new electronic control for the transmission, effortless, more precise and ergonomic.



↑ Easy selection of the combine systems - concave (front and rear), sieves (upper or lower) and Turbo - separator with easy adjustment via 3 touch buttons. Header controls for mode, height and soil pressure adjustment. Joystick control for the BALANCE system provides intuitive and accurate adjustment.



↑ At the rear of the armrest are the controls for 4wd, park brake, grain tank opening, MMI and the new dashboard with USB outlets.

State of the art on board control system – easy and precise adjustments and a smoother control of the transmission for TOP comfort for the operator.



STREET

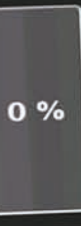

0 %

4 / 4

20.0 l/h

8 h



4.0 km/h

4.0 km/h



F1 F2 F3

03:02 pm
5 Feb



iMONITOR



DEUTZ-FAHR

THE NEW iMONITOR.

All systems in view – at a glance.

Clear, simple and always up to date, the new iMonitor defines a new era in combine management. All combine parameters and functions are managed directly on the 8" iMonitor, with the possibility to save and export all performance data. User friendly philosophy to easy identify the right page and convenient short-cuts to jump from one page to the other quickly and without stopping harvesting. Intuitive

setting of the parameters thanks to the touch-screen pad. The street page is displaying mainly speed and vehicle related information. The field page shows the status and performance of the combine while harvesting. The adjustment are precisely made with easy to read parameter system. A brand new cutting header page allows the user to control and adjust all relevant settings in one shot.



↑ Dedicated field view with all information needed while harvesting and with the possibility to personalise the display.



↑ All combine parameters and functions are managed directly on the iMonitor.



↑ Easy adjustment of the touchscreen monitor position.



EVERYTHING UNDER CONTROL!

Thanks to state-of-the-art-technology.

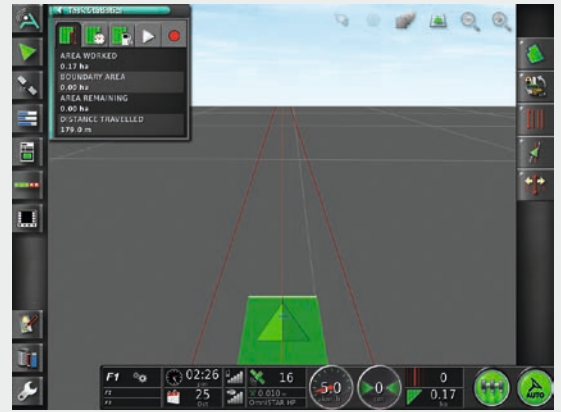

↑ 12" iMonitor integrates the software to manage Agrosky and Yield monitor.

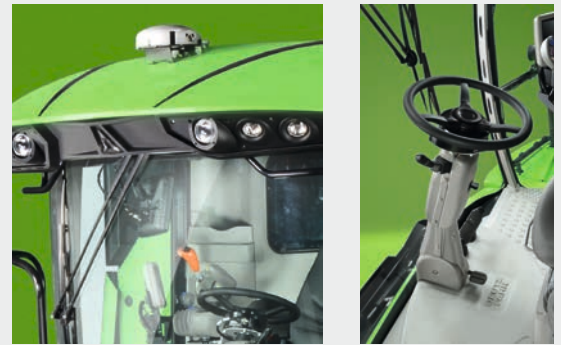

↑ Easy installation of the precision farming systems, full integration of the electrical steering, the GPS antenna, the yield sensors and the Isobus ECU.



↑ Complete Yield and moisture system. Isobus system fully compatible with the Agrosky GPS Antenna for more detailed Yield mapping.

Evolving with the needs of modern agriculture, DEUTZ-FAHR C9300 series are ready to host the latest technologies to increase efficiency. For more precise driving especially on long fields, Agrosky, the assisted steering system, with EGNOS or RTK accuracy, is the right solution. The yield monitor system will let the operator check constantly the moisture, quantity and quality of the crop and adjust the combine consequently. Thanks to the system of yield sensor monitoring, moisture, weight of the crop and position of the combine, TOP accuracy and efficiency is guaranteed.

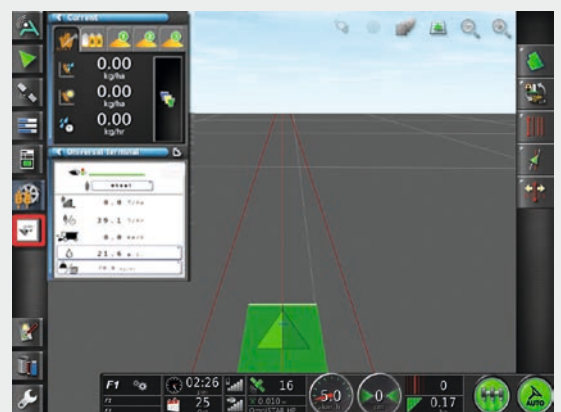

↑ Possibility to check Yield mapping while using the assisted steering.

CONNECTED FARMING SYSTEMS.

Precision is the basic prerequisite for productivity.

Connected Farming Systems combines a large number of digital solutions for efficient and comfortable operation of tractors and combine harvesters. This includes reliable, automatic high precision track guidance systems, ISOBUS applications, data management and fleet management. The iMonitor3 is at the core of the operation of most applications – it is the central, user friendly control element.

SDF Guidance

Modern steering systems save resources, increase convenience and productivity and ensure reliable precision. You can rely on high reliability even in difficult working conditions such as fog or night time. Satellite navigation provides the basis for this. You can choose the system that best suits your operation.

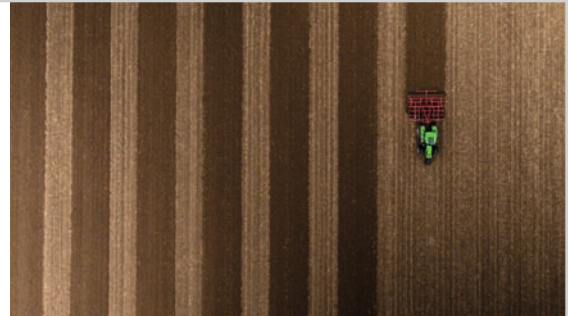

SDF Fleet Management

Optimise operations. Increase efficiency. The connectivity solutions from SDF keep you connected at all times. It allows convenient managing of relevant data. The BTM (Basic Telematic Module) is the entry level for transmission of tractor data. Telemetry data are sent to e.g. a smartphone via a Bluetooth connection. All relevant data can be called up with an app. In the Pro version, the CTM (Communication Telematic Module) transfers the data directly to the office over the Internet using an integrated e-SIM card.



SDF Data Management

Efficient data management is becoming increasingly important for optimising work processes. SDF uses standard file formats for reliable data exchange so customers can keep an overview at all times and data are transferred in a coordinated manner. With the agrirouter, we offer a universal data exchange platform that allows farmers and contractors to exchange data between machinery and agricultural software applications from a wide range of manufacturers. The agrirouter simplifies data exchange and therefore work processes, reduces office work and improves economic efficiency.

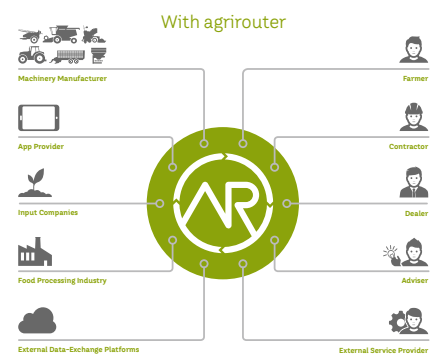

ISOBUS

Electronics make agricultural machinery safer, more powerful, more precise and more efficient. The driver can use ISOBUS applications to individually control all implements with one single monitor – the iMonitor3 is also the central control element for all ISOBUS applications. The iMonitor3 easily manages tasks such as assigning AUX-N functions, processing application maps or automatic switching of up to 200 sections. A great number of functions are even available without activation.



CONNECTED FARMING SYSTEMS.

Precision is the basic prerequisite for productivity.

Connected Farming Systems combines a large number of digital solutions for efficient and comfortable operation of tractors and combine harvesters. This includes reliable, automatic high precision track guidance systems, ISOBUS applications, data management and fleet management. The iMonitor3 is at the core of the operation of most applications – it is the central, user friendly control element.

SDF Guidance

Modern steering systems save resources, increase convenience and productivity and ensure reliable precision. You can rely on high reliability even in difficult working conditions such as fog or night time. Satellite navigation provides the basis for this. You can choose the system that best suits your operation.

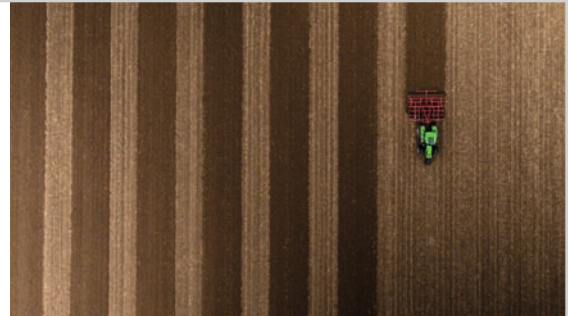

SDF Fleet Management

Optimise operations. Increase efficiency. The connectivity solutions from SDF keep you connected at all times. It allows convenient managing of relevant data. The BTM (Basic Telematic Module) is the entry level for transmission of tractor data. Telemetry data are sent to e.g. a smartphone via a Bluetooth connection. All relevant data can be called up with an app. In the Pro version, the CTM (Communication Telematic Module) transfers the data directly to the office over the Internet using an integrated e-SIM card.



SDF Data Management

Efficient data management is becoming increasingly important for optimising work processes. SDF uses standard file formats for reliable data exchange so customers can keep an overview at all times and data are transferred in a coordinated manner. With the agrirouter, we offer a universal data exchange platform that allows farmers and contractors to exchange data between machinery and agricultural software applications from a wide range of manufacturers. The agrirouter simplifies data exchange and therefore work processes, reduces office work and improves economic efficiency.

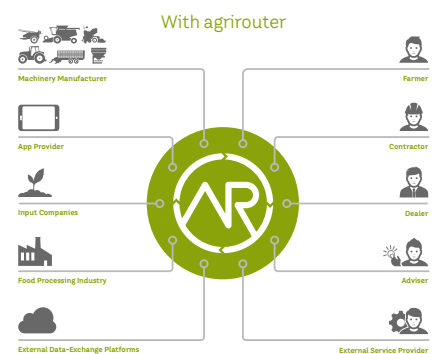

ISOBUS

Electronics make agricultural machinery safer, more powerful, more precise and more efficient. The driver can use ISOBUS applications to individually control all implements with one single monitor – the iMonitor3 is also the central control element for all ISOBUS applications. The iMonitor3 easily manages tasks such as assigning AUX-N functions, processing application maps or automatic switching of up to 200 sections. A great number of functions are even available without activation.





THE FINEST CUT.

For all harvest conditions.



A wide range of grain cutting header for the most common uses but with unique features. Standard grain headers up to 9 m, with one-piece construction which means optimal weight distribution, long life and reliable performance on any terrain and harvesting conditions. The large diameter feeder auger has deep flights. This, together with the auger fingers distributed in a spiral fashion along the entire auger, ensures continuous feeding and productive crop transfer. Large reel with proportional speed, adjusting automatically according to the combine ground speed. This solution keeps a constant flow and therefore better threshing.



↑ The SCHUMACHER EASY CUT II system: cutting rate of 1220 strokes per minute but reduced wear and power absorption.



↑ Special guide rollers (optional) reduce vibration and wear even further.



↑ Robust skid plates integrate the ground sensors to control the position of the cutting header also on irregular terrains.

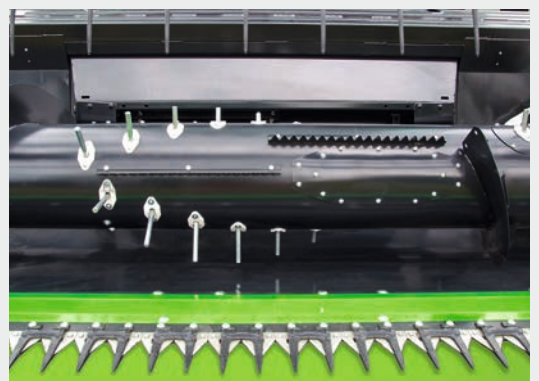

↑ Large diameter of the intake auger with adjustable fingers in spiral all along the entire cutting width.

MORE VERSATILITY.

For contractors and farms – worldwide.

More crop types, more opportunities, more equipment requirements. DEUTZ-FAHR headers are able to answer multiple needs of contractors as well as farmers all around the world and through the whole harvesting season.



↑ The range of VARICROP headers includes 3 sizes 5.5, 6.5, and 7.5 m.



↑ For rape harvesting there is a specifically designed kit which can be applied to the standard DEUTZ-FAHR headers up to 7.2 m.



↑ The lower bed can be extended up to 700 mm hydraulically. The vertical side knives are hydraulically driven and foldable reducing the operation of conversion of the cutting header for rape harvesting.



↑ For sunflower harvesting a kit is designed to be applied to DEUTZ-FAHR standard headers up to 7.20 m wide.



DEUTZ-FAHR

C9306
TSB



QUALITY AND PRODUCTIVITY.

Successful harvesting on any terrain.

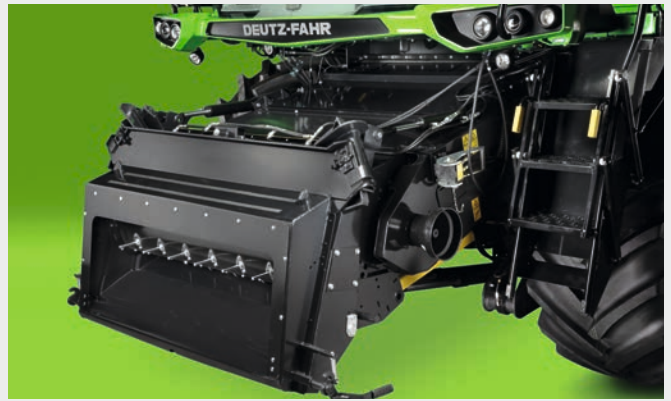

↑ For all models, an electro hydraulic cutting angle adjustment system (standard on BALANCE models) is available to optimise the position of the header. The Autocontrol function also helps the header to follow the uneven terrain.



↑ Simple and intuitive joystick to control the BALANCE system. Automatic and Manual function, Neutral position and street function. Ergonomic, comfortable position integrated in the control armrest.



↑ The 25 t capacity axles allow the machine to work in the most extreme conditions, ensuring utmost reliability and, above all, driver safety.

Thanks to the DEUTZ-FAHR Balance system, the combine always works in a horizontal position, offsetting lateral gradients of up to 20% and longitudinal gradients of up to 6%. The inclination of the combine harvester is detected by potentiometers placed on the wheels and the data is processed by an electronic control unit that immediately sends control impulses to the hydraulic system. The threshing system, the straw walkers and the cleaning system move the crop evenly, ensuring high productivity.

The BALANCE function is activated by simply pressing a button on the armrest, with the possibility of manually adjust the machines position. The automatic cutting angle adjustment, a DEUTZ-FAHR exclusive, ensures constant feeding as the gradient changes and, always having a constant cutting angle, avoids potentially damaging ground contact and ensures high harvesting speed.

TOP FEEDING, BETTER THRESHING PERFORMANCE.

Thanks to continuous, constant material supply to the threshing unit.

Nothing is left to chance in the C9000 Series: the long and wide feeder elevator has alternating feeder slats fixed to three chains with drive support shafts that prevent slippage and allow large headers to be mounted. The front finger roller allows the crop to be continuously and consistently fed, avoids feeder and threshing system overloading and significantly reduces wear and maintenance costs. The consistent crop flow provided by the "Extra Feeding" feeder roller delivers a more even feed of crop to the threshing systems resulting in better performance and less power requirement.

The new hydraulic reverser which reverses both the feeder and header eliminates any possibility of feeder system overload. Adding to this is an exclusive electro hydraulic header cutting knife angle regulator system, (standard on BALANCE models). Together, these features help to ensure that the threshing system is fed continuously and uniformly.



↑ Lateral tilt up to 20% and hydraulic cutting angle adjustment with automatic function.

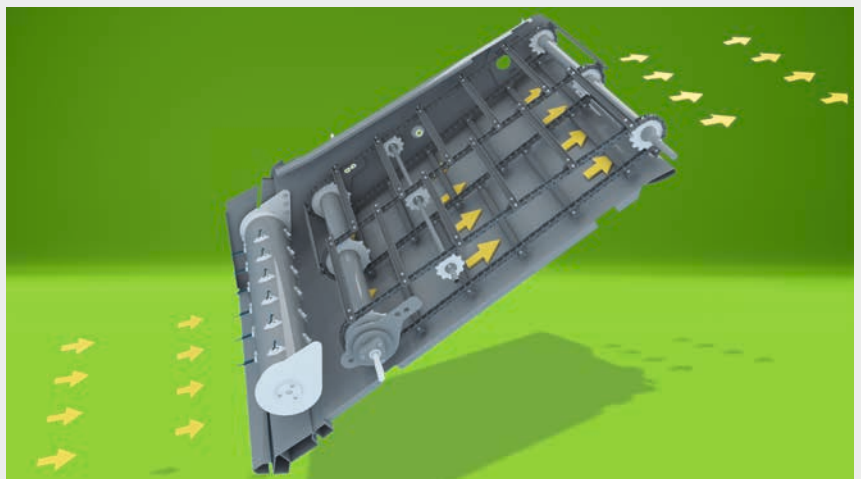
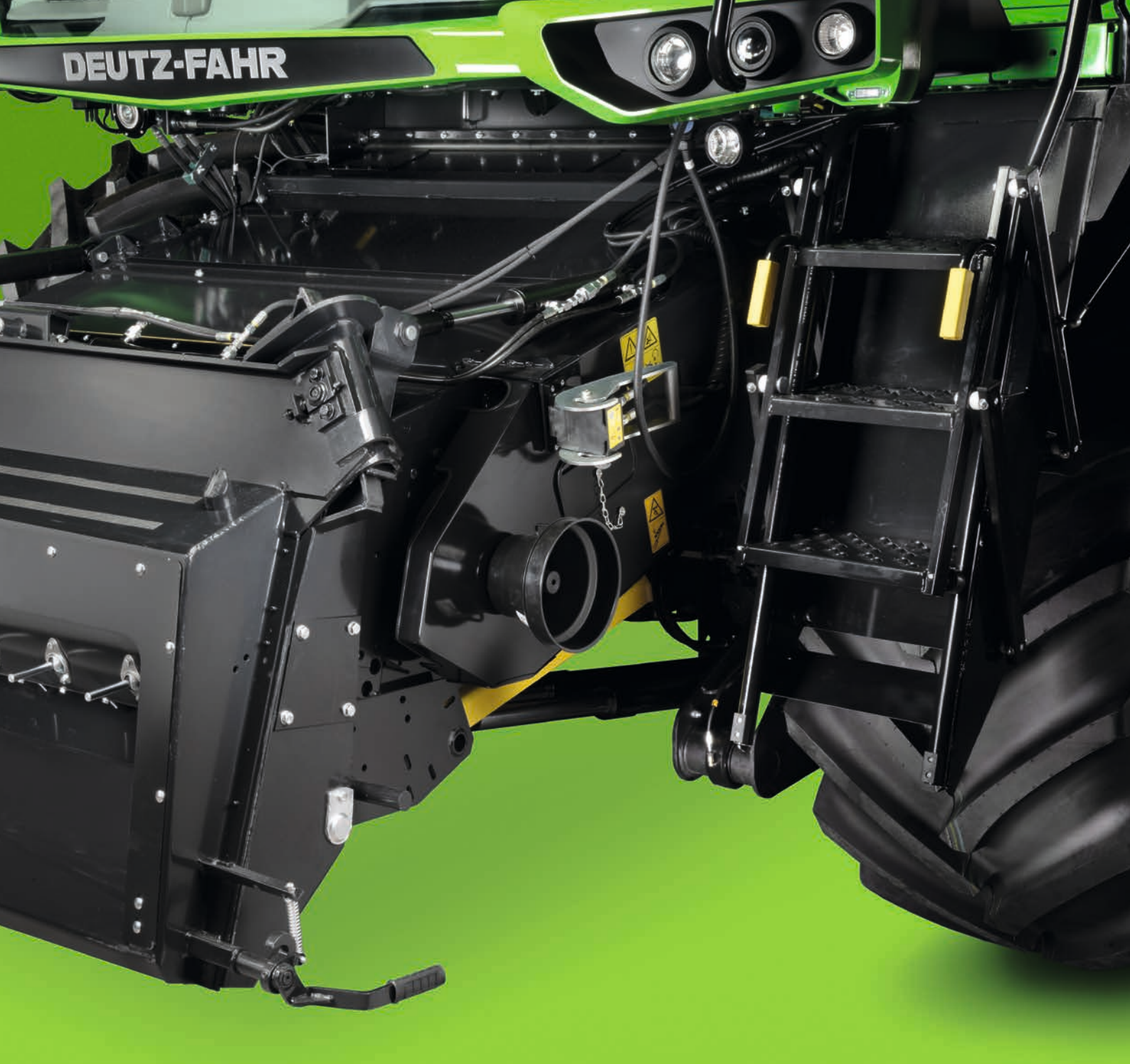

↑ Inside the feeder alternating feeder slats distribute the crop quickly and evenly. The finger length can be easily adjusted in 3 different positions to be adapted to all type of crops.

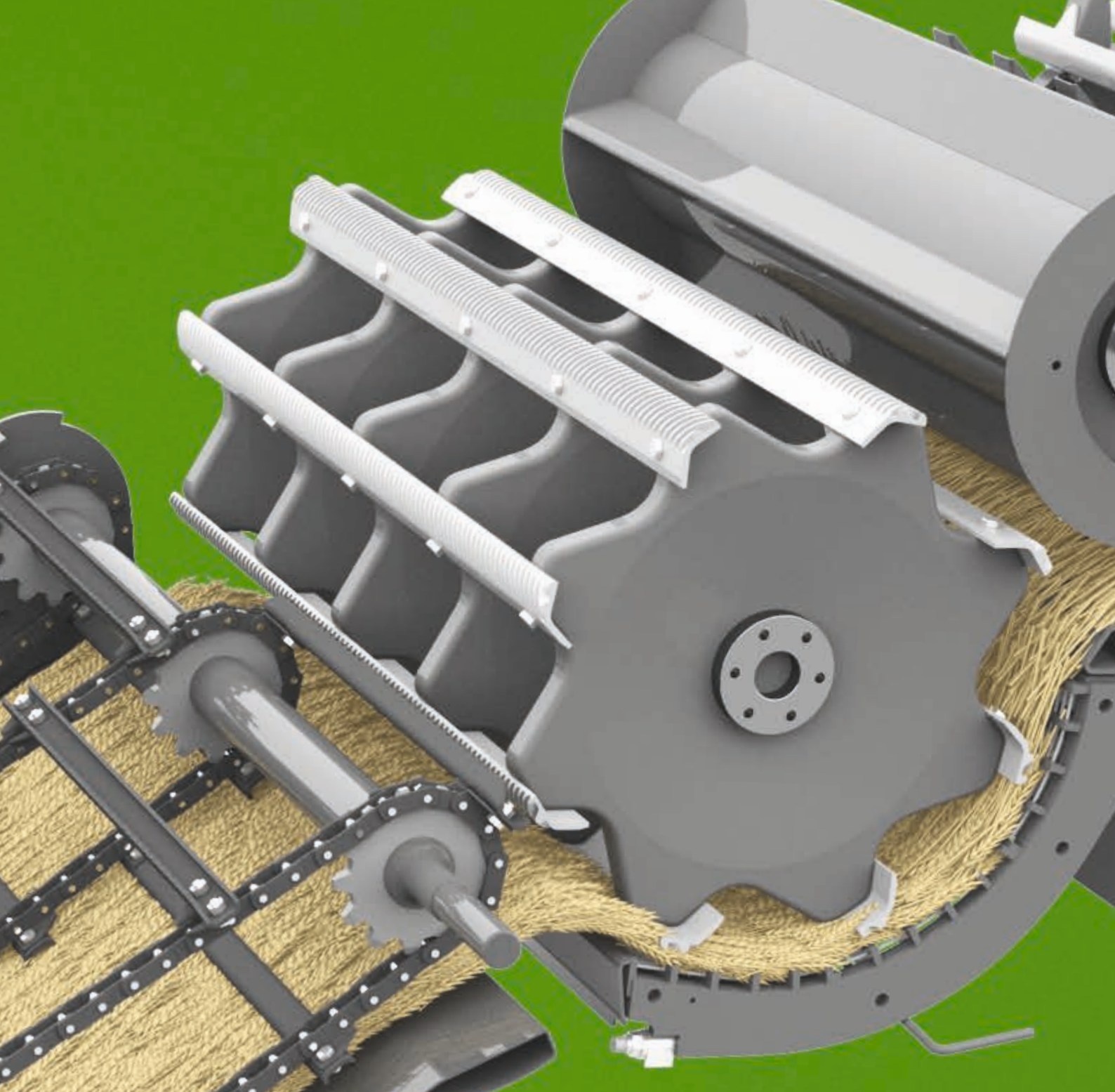

EXTREMELY HIGH PRODUCTIVITY TOGETHER WITH HIGH QUALITY OF STRAW AND GRAIN.

The C9000 Series with Maxi-Crop system.

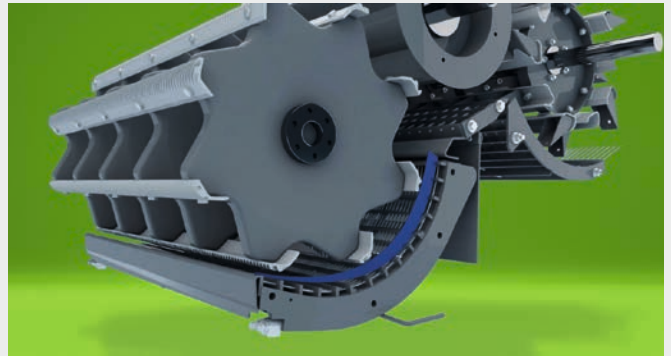
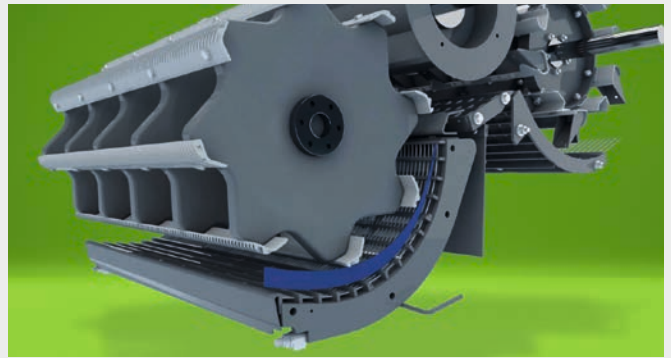

📏 The clearance between the concave and the threshing drum can be independently adjusted at both the front and rear via electric actuators controlled by the Commander Control.

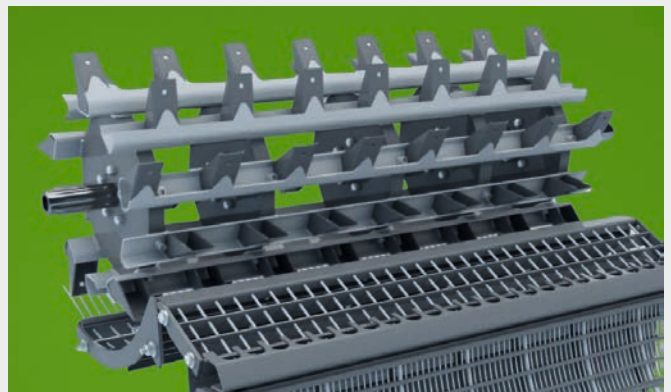

📏 With a large diameter of 590 mm and the dedicated concave, the Turbo-separator can achieve productivity increases up to 20%. The exclusive 5-position electrical adjustment allows the system to vary according to the crops and to straw conditions granting best straw quality for baling. The Turbo separator can also be adjusted in 2 speeds: 775 rpm for small seeds (e.g. Wheat, Barley, Oats, Alfalfa) and 410 rpm for heavy seeds (e.g. Maize, Beans and Peas).

To dominate in the field with maximum productivity, DEUTZ-FAHR C9000 Series combine harvesters have the "Maxi Crop" system that ensures versatility and maximum threshing efficiency even in the toughest conditions. The construction robustness and threshing geometry of these combine harvesters provide extremely high productivity while handling the grain and straw with care to keep the quality high. The concave with 15 rasp bars arranged with a wrap angle of 121° ensures superior threshing and separation efficiency while taking maximum care of grain and straw quality.

The Threshing drum diameter is 600 mm, it integrates 8 threshing bars and has a width of 1,270 mm for the 5 straw-walker models or 1,520 mm for the 6 straw-walker models.

The distance between the concave and the threshing drum at the input and output can be independently adjusted at the front and rear via electric actuators controlled from the iMonitor.

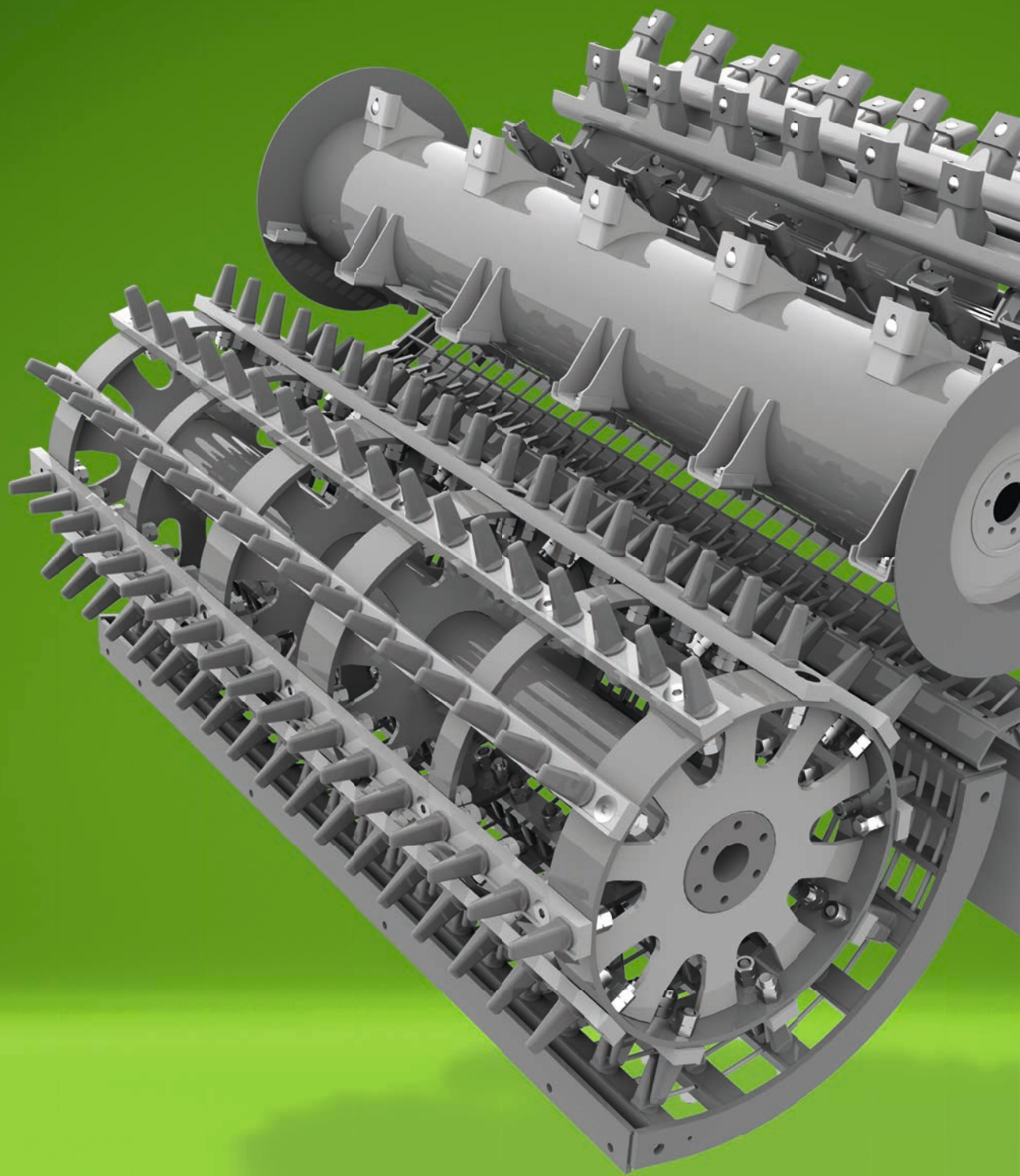

MULTIPURPOSE PHILOSOPHY.

Fast and easy conversion thanks to numerous segment options.

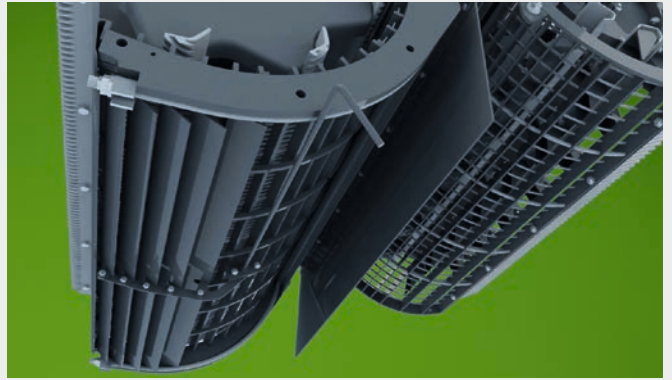
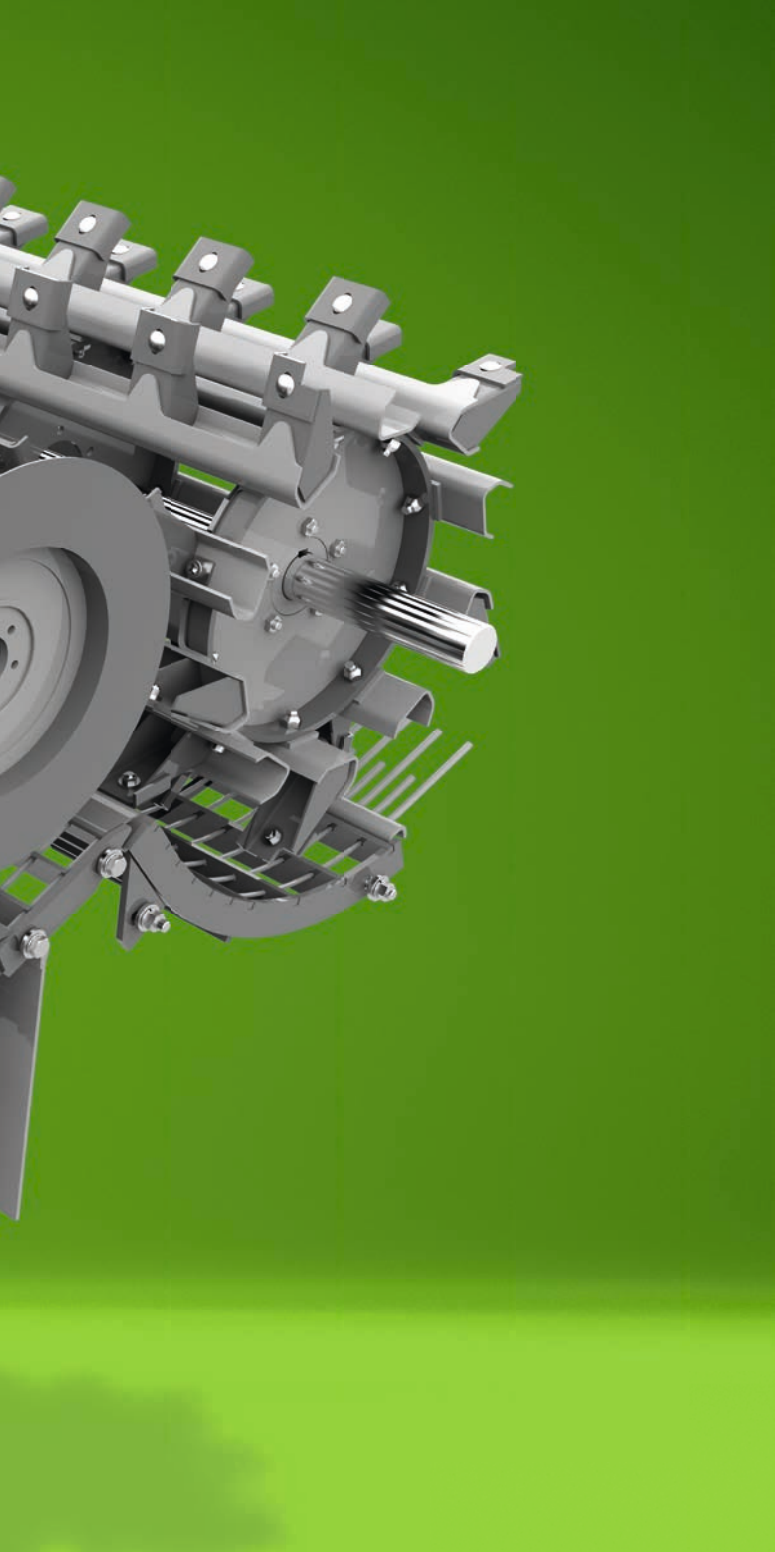

↑ Tool free de-awing plates insertion standard on all versions.



↑ Segmented concave to easily adapt the combine to different crop or different harvesting conditions with spacing between the wires available from 11 mm to 20 mm.



↑ Optional threshing drum speed reducer to set the threshing drum rpm from 1250 to 625 as maximum speed and from 420 to 210 rpm as minimum speed. This kit is suggested while harvesting maize.

The unique DEUTZ-FAHR construction of the concave divided in 3 segments, make the transformation fast and simple, allowing the harvest of different crops thanks to the wide number of segment options available. For Rice harvesting, DEUTZ-FAHR offers a dedi-

cated solution with threshing drum and toothed concave and special transport augers resistant to the abrasive crop. The threshing drum and concave of the rice harvesting kit are designed with special tooth with conical shape for better separation and less wearing.



↑ Long straw-walkers with open bottom, and a total shaking surface of 6.92 m² for the C9306 models and 5.80 m² for the C9305 models, manage huge quantity of straw.



↑ The Powerful turbine ventilation reaches the entire cleaning area and separation surface.



ENHANCED SEPARATION AND CLEANING.

For perfectly clean grain.

The large surface of the straw walkers, their length and stroke allow separation of even the last grain from the straw. Their open construction prevents any blockages with particularly wet crops.

The dedicated return pan ensures that the crop reaches the grain preparation pan evenly distributed. The first step of the straw walkers is deeper, to slow the crop flow exiting the threshing system and improves the efficiency at the first separation stage. The grain preparation pan ensures perfect removal of straw and chaff thanks to a powerful fan.

The large surfaces of the sieving system (5.28 m² for C9305 models and 6.32 m² for C9306 models), the 44 blade turbine cleaning fan and the double step pre-sieve transfer perfectly clean grain to the grain tank. Another DEUTZ-FAHR exclusive feature is the dual independent return system which evenly distributes the crop directly on the grain preparation pan to avoid overloading the threshing system and creating unnecessary grain cracking. Any heads not threshed can be re-threshed by 2 beaters which send them completely threshed to the grain preparation pan. The re-thresher has two interchangeable friction plates (adaptable to any crop) to ensure maximum performance in all operating conditions.



↑ DGR System: returns elevators on both sides of the machine with special friction plates to thresh the crop while returning it onto the preparation pan.



LARGE VOLUME, RAPID UNLOADING.

Productivity increase by reducing idle times.

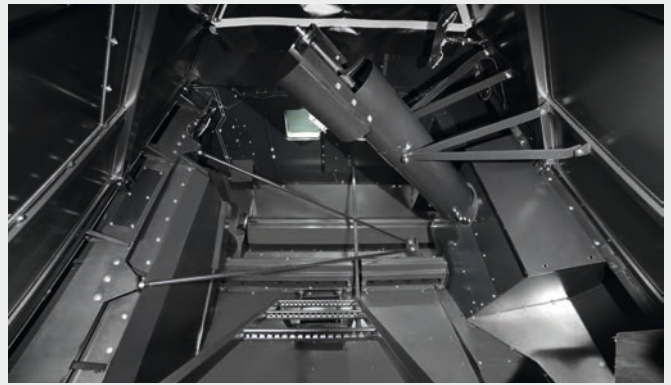

Big feeding auger. Two unloading augers in the grain tank to rapidly empty the grain tank.



Integrated light and camera on the unloading pipe to check the unloading operations.



Dual inspection window in the cabin, easy sample pick up tray just outside the cabin.

The 10,500 litre grain tank with 120 lt/sec unloading speed increases productivity by consistent reduction of dead times. The significant engine power allows to keep working during unloading with no loss in productivity.

Two augers inside the grain tank as well as a large diameter auger in the unloading pipe assure the maximum unloading speed. To pre-

vent loss of grains while folding back the unloading pipe, the auger inverts the rotating direction automatically.

The new COMMANDER CAB VI features dual grain tank inspection windows, offering the operator a clear view of the crop harvested.

The lighting package and the camera option provide the driver with outstanding vision during unloading.



PERFECT STRAW, POWERFUL STRAW CHOPPER AND CHAFF SPREADER.

Full power. Full precision. Perfect quality.



The long straw treated gently by the threshing system and the straw-walkers is discharged in a large tall swath in perfect conditions. The C9300 Series has a wide and direct opening just under the straw-walker to ensure the straw runs as straight as possible. The DEUTZ-FAHR high cutting density straw chopper ensures that the cut area is left ready for subsequent farming activities. The wide working area of the chopper spreads ensures the chopped materials are evenly spread across the entire area.

Easy access to the knives and counter-knives minimizes maintenance and setting up times. For even more effective material distribution, the straw chopper may also be equipped with electrically adjustable

deflectors, to adapt spreading to wind conditions. With a new conveyor and two 4-blade rotors, the chaff spreader distributes the material leaving the sieves across the same working area as the straw chopper to obtain an ideal straw/chaff mixture and facilitate the breakdown of organic material into the soil.



↑ Big straw-hood discharge chute to maximize the product flow of the long straw.



↑ Straw-chopper unit with spreader adjustable in 3 positions. The spreader unit is converted to a chute for the long straw while not in use.



↑ The spread of the chopped straw covering the entire width of the cutting header in all conditions. Integrated chaff spreader for an even preparation of the soil.

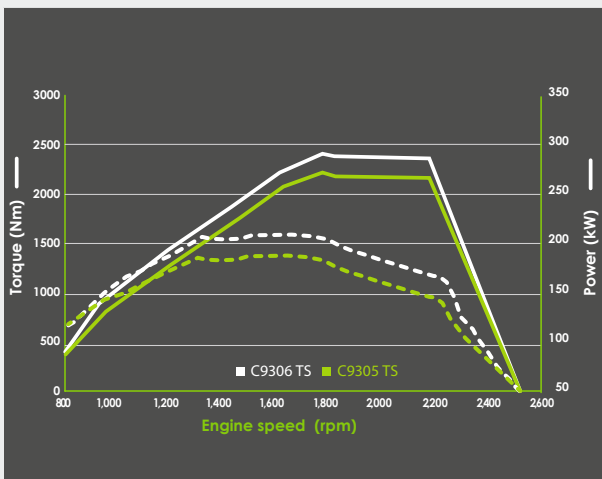

↑ Maximized efficiency, constant maximum power always guaranteed.



↑ Pre-cleaning engine air filter with automatic self-cleaning system.



↑ 750 litre fuel tank



EXCEPTIONAL PERFORMANCE. LOW CONSUMPTION.

Mercedes-Benz engines 7.7 litre type OM936 stage V, EGR, SCR, common-rail injection, 24 valves, electronic control.

The exclusive DEUTZ-FAHR design provides power take off on both sides of the engine. Therefore the hydraulic and mechanical functions are separated and have direct transmission drivelines which reduces significantly power losses and wearing parts.

The exclusive power take off architecture is combined with the new generation of Mercedes Benz engines, with 7,7litres displacement and 2 power levels: 260kW/353 hp for the 5 Straw-walkers models and 280kW/381 hp for the 6 Straw-walkers models. These innovative engines are able for the first time ever to grant a constant power output using the real potentiality of the engine removing the needs to have overboost settings to work out extra load peaks.

The result is more efficiency, less consumption, improved performance of the after-treatment system, smoother power transmission to belts and chains. All versions have a Common Rail injection, 24 valves and an electronic governor. The nitrogen oxide emissions are reduced to the minimum thanks to the combination of 3 systems with extraordinary efficiency: EGR (Exhaust Gas Recirculation) valve and an SCR (Selective Catalyst Reduction) system, and DPF (Diesel Particulate Filter).

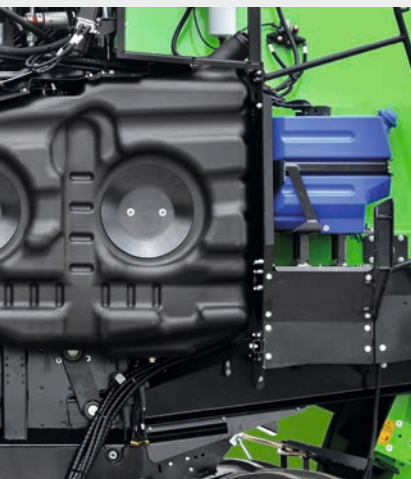

76 litres AdBlue tank.



EXCELLENT TRACTION.

On any terrain.



Smooth control of the transmission with the electronic COMMANDER STICK. The direction is selected by the combination of the consent button and moving the lever toward the desired direction. The greater the movement, the faster the speed. Cruise control maintains the optimum working speed, while small adjustments can be made by pushing or pulling back the COMMANDER STICK to increase or reduce speed respectively.



Heavy duty rubber tracks with integrated final drive line allows the combine to keep the overall width under 3.5 m. The compaction is at the lowest level while the traction is at its maximum.



Heavy duty adjustable rear axle available also with the exclusive 4WD anti-skid system.

TOP transmission, TOP traction and TOP control; the C9300 combines will be always be delivering the maximum of all 3 features. Hydrostatic transmission with 4 speeds electronically controlled the cruise control system increases the comfort and let the operator

concentrate on the harvest operations. The 4WD axle integrates the unique antiskid system which check the traction of each wheel and manages the hydraulic oil flow to reduce the slippage of the wheels.



EASY, FAST MAINTENANCE.

Because time is money.



↑ Tool free dismantling of the air filters of the cabin.



↑ Full access to the radiators: wide opening and dedicated platform.



↑ Easy access to adjust and check the chains on the feeder channel.

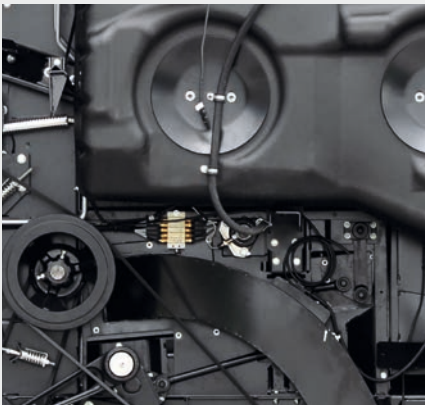

↑ Grouped greasing points (left). Automatic greasing system (right).

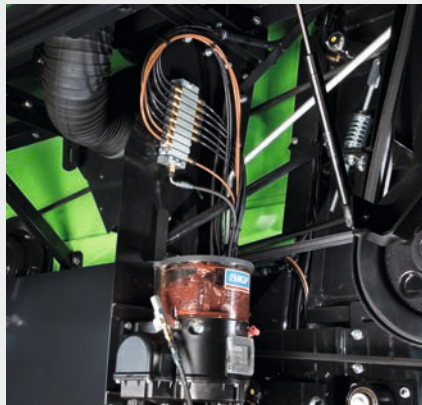

↑ The segments of the preparation pan are easily extracted from the stone trap.



↑ Easy access to the fuse box.



↑ Perform and control the calibration of all main systems directly from the iMonitor.

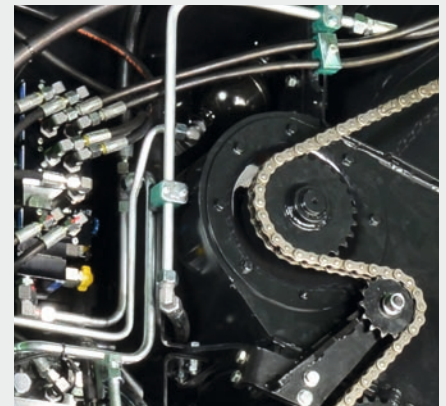

↑ All hydraulic valves grouped on the left side for easy access and check.

The wide side panel opening allows full access to all of main systems of the combine. On the right side all main mechanical clutches as well as the electric systems are located.

The access to the engine compartment and the radiators is facilitated thanks to a removable ladder, very useful while making all round checks of the combine before and after the harvest.

Technical Data	C9000 SERIES			
	C9305TS	C9305TSB	C9306TS	C9306TSB
HEADER				
With option			5.40 - 6.30 - 7.20 - 9.00	
Hydraulic cutting height adjustment	mm		from -300 to +1,370	
Cutting height indicator			●	
Oil-immersed planetary knife drive gearbox (1,220 cuts / min.)			●	
Long right and left crop dividers, fixed			●	
No. Of crop lifters			15 to 29, depending on cutting width	
Automatic adjustment of ground pressure, pre-selection of cutting height with height indicator			●	
AutoControl (with lateral floating)	○	●	○	●
Adjustment of the cutting angle (electrohydraulic)			●	
Trailer tow hitch			●	
Header transport trolley			○	
Hydraulic multicoupler			●	
Automatic towing hitch			○	
Rapeseed header conversion kit with hydraulic controlled side cutter on right			○	
Side cutter for rapeseed on left with separate hydraulic control (only with rapeseed header)			○	
Sunflower header conversion kit			○	

Technical Data	C9000 SERIES			
	C9305TS	C9305TSB	C9306TS	C9306TSB
PICK-UP REEL				
6-bar reel with hydraulic height adjustment			●	
Hydraulic horizontal adjustment			●	
Electrical speed control	rpm		16 to 45, infinitely variable	
Automatic adjustment of reel rpm to travel speed			●	
VARICROP				
Width option		5.00 - 5.50 - 6.50 - 7.50		5.50 - 6.50 - 7.50
Hydraulic cutting height adjustment	mm		-300 / +1370	
Long right and left crop dividers, fixed			●	
Crop lifters (N° depending on cutting width)			○	
AutoControl (with lateral floating)			●	
700 mm stepless hydraulically movable cutterbar with stainless steel cover			●	
Hydraulic angle adjustment			○	
Integrated foldable side knives			●	
Integrated hydraulic reel drive inside the reel tube			●	
Sunflower header conversion kit			○	

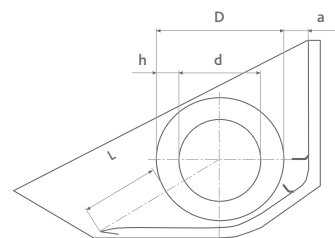
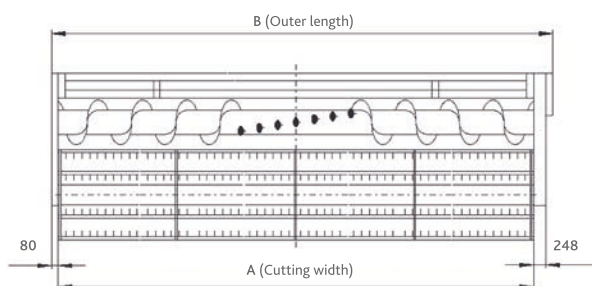

CEREAL HEADERS				
Type	A (mm)	B (mm)	Weight (Kg)	Cereal headers in mm
4.20 m	4,187	4,515	1,280	L = 480
4.80 m	4,796	5,124	1,420	D = 610
5.40 m	5,406	5,734	1,540	d = 350
6.30 m	6,320	6,648	1,760	h = 130
7.20 m	7,235	7,563	1,980	a = 130
9.00 m	9,000	9,622	2,580	

VARICROP HEADERS				
Type	A (mm)	B (mm)	Weight (Kg)	Varicrop headers in mm
5.00 m	5,050	5,680	2,190	L = 510-1560
5.50 m	5,510	6,140	2,280	D = 610
6.50 m	6,500	7,130	2,500	d = 410
7.50 m	7,500	8,120	2,710	h = 100
				a = 50

Technical Data		C9000 SERIES			
		C9305TS	C9305TSB	C9306TS	C9306TSB
TRESHING DRUM					
Diameter	mm	600			
Width	mm	1,270		1,521	
Bars	n°	8			
Electrical variator	rpm	420 - 1,250			
Threshing drum speed reducer (optional)	rpm	210 - 625			
CONCAVE					
Bars	n°	15			
Wrap angle	degrees	121			
Separation surfaces	m ²	0.95		1.13	
Multi-segment concave		○			
Laterally operated de-awner plates		●			
Electrical adjustment of concave inlet / outlet		●			
Conversion for maize harvesting, grain or CCM		○			
Conversion for rice harvesting		○			
TURBO SEPARATOR					
Diameter	mm	590			
Rotation speed	rpm	775-410			
Electrical adjustment from cab through 5 positions		●			
Separation surfaces	m ²	0.81		0.97	
Wear plates for heavy duty applications		○ (● with rice-harvesting equipment package)			
STRAW WALKER					
Elements	n°	5		6	
Steps	n°	4			
Straw walkers open		●			
Ball bearing mounts		●			
Straw walker surface area	m ²	5.80		6.92	
Total separation surface	m ²	7.56		9.02	
Walker return surface		●			
Electronic straw walker speed control		●			
STRAW CHOPPER - CHAFF SPREADER					
Built-in straw chopper with manually adjustable spread width		○			
Electrical spreading width adjustment		○			
Chaff spreader with conveyor integrated in the sieves		○			

Technical Data	C9000 SERIES			
	C9305TS	C9305TSB	C9306TS	C9306TSB
CLEANING SYSTEM				
High performance crossflow fan			●	
Pre-sieve			●	
Sieve box illumination			●	
Opposed action sieves			●	
Total ventilated sieve area	m ²	5.28		6.32
TAILING RETURN SYSTEM				
Electronic control of returns level and overload			●	
Independent L / R returns with re-threshing system			●	
GRAIN TANK				
Lifting / Capacity	litres		10,500	
Discharge in any position			●	
Visual and audible grain tank level indicator			●	
Interior light / Grain sampling from driving position			●	
Extra long 6 m discharge pipe			●	
Discharge speed			120 lt / sec.	
ENGINE				
Stage V 4 valve Common Rail engine		Mercedes Benz OM936 7.7 LITRES		
Maximum power		260 / 353		280 / 381
Fuel tank	litres		750	
AdBlue [®] tank	litres		76	
TRANSMISSION / BRAKES / STEERING				
Hydrostatic transmission with 4-speed gearbox			●	
Forward speed / Reverse speed	km / h	0 - 30.0 / 0-14.0		
Pedal operated hydraulic brake, usable as independent brake, mechanical parking brake			●	
"BALANCE" LEVELLING SYSTEM				
Complete levelling of the combine		-	●	-
Compensation for transverse / longitudinal slopes		-	20% / 6%	-
				20% / 6%

Technical Data	C9000 SERIES			
	C9305TS	C9305TSB	C9306TS	C9306TSB
TYRES				
front 620/75 R30 168 A8	○		-	
front 650/75 R32 167 A8			●	
rear 405/70 R20 155 A2			●	
front 800/65 R32 STR 172 A8			○	
rear 500/60 -22.5 10 PR			○	
front 710/75 R34 178 A8	○	-	○	-
rear 600/50 R22.5 165 A8			○	
rear 540/65 R24 146 D			○	
Rubber track with 4 rollers undercarriage and 915 mm track	○	-	○	-
Rubber track with 4 rollers undercarriage and 716 mm track	○	-	○	-
CAB				
CommanderCab VI with tinted, thermally insulated glass providing panoramic visibility, comfort driving seat with armrest, passenger seat			●	
CommanderControl and COMMANDER STICK for electrical control of operation of cutter bar, threshing system, concave, TS, grain tank unloading and threshing system parameter setting			●	
8" touch screen iMonitor			●	
10 work lights on cab, 1 work light on grain tank, 2 rear work lights, 3 beacons			●	
Electric mirrors, left and right			●	
Work Visibility pack: work lights on sides, under-cab and on handrail			○	
Maintenance visibility pack (4 on side of the combine, 1 in the engine compartment)			○	
Camera kits: 3 cameras (rear, emptying pipe and tow hitch) IR and colour 7" monitor or 12" iMonitor (with Agrosky)			○	
Removable 21l capacity fridge			●	
2 xenon work lights			○	
Agrosky assisted steering (EGNOS electric steering)	○	-	○	-
Moisture /Yield monitor system			○	
SAFETY DEVICES				
Safety clutch for feed passage top shaft, feed auger, reel, straw walker drive and grain auger			●	
Electronic speed control for straw walker, grain elevator and tailings return			●	
Cutter bar emergency stop			●	
Fire extinguisher			●	
MAINTENANCE				
Manual centralised lubrication system, greasing points: 8 on left, 6 on right			●	
Automatic centralised greasing system with approx. 60 lubrication points			○	
Compressed air system: 60 litre capacity, total of 3 outlets (2 on sides, 1 in engine compartment)			○	

Technical Data			C9000 SERIES			
			C9305TS	C9305TSB	C9306TS	C9306TSB
DIMENSIONS						
a) Track width*	front	mm	2,630			
	rear	mm	2,393			
b) Width* without cutter bar		mm	3,296			
c) Width with cutter bar	with 4.80 m cutter bar	mm	5,124		-	
	with 5.00 m cutter bar	mm	5,680		-	
	with 5.40 m cutter bar	mm		5,734		
	with 5.50 m cutter bar	mm		6,140		
	with 6.30 m cutter bar	mm		6,648		
	with 6.50 m cutter bar	mm		7,130		
	with 7.20 m cutter bar	mm		7,563		
	with 7.50 m cutter bar	mm		8,120		
	with 8.50 m cutter bar	mm		9,110		
	with 9.00 m cutter bar	mm		9,622		
	d) Height to lower edge of grain tank discharge pipe with standard tyres		mm	4,557		
e) Distance between side wall of cutter bar and grain discharge pipe	with 4.80 m cutter bar	mm	3,410		-	
	with 5.00 m cutter bar	mm	3,410		-	
	with 5.40 m cutter bar	mm		3,105		
	with 5.50 m cutter bar	mm		2,996		
	with 6.30 m cutter bar	mm		2,648		
	with 6.50 m cutter bar	mm		2,500		
	with 7.20 m cutter bar	mm		2,191		
	with 7.50 m cutter bar	mm		2,006		
	with 8.50 m cutter bar	mm		1,511		
	with 9.00 m cutter bar	mm		1,246		

Technical Data		C9000 SERIES			
		C9305TS	C9305TSB	C9306TS	C9306TSB
DIMENSIONS					
f) Wheelbase	mm	3,890	3,860	3,890	3,860
g) Length without cutter bar	mm			9,240	
h) Length with cutter bar-crop dividers folded in (mm)	mm			10,890	
i) Grain tank height	mm			3,990	
Weight without header	kg	16,900		17,500	18,300

- STD ○ OPT
- Not available
- * Optional or standard depending on version

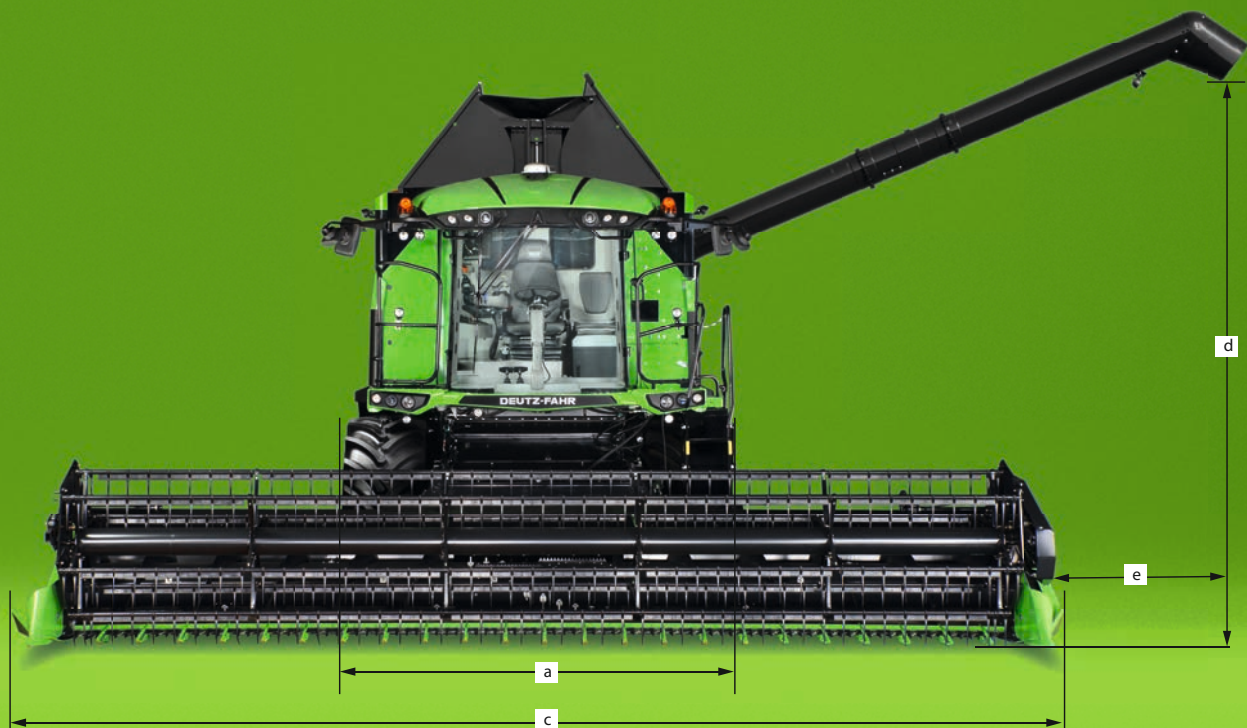

The technical specifications and images herein are purely indicative. DEUTZ-FAHR reserves the right to update this information at any time without notice.

Your DEUTZ-FAHR sales partner

Marketing-Communication Service – Code 308.8308.3.4-5 – 10/19
© Konzept und Design – RaapSteinert Kommunikation



For more information, please contact your DEUTZ-FAHR sales partner
or visit deutz-fahr.com.

DEUTZ-FAHR is a brand of  SDF